Globosilo

Outdoor silos in stainless steel with vibrating cone or fluidized bed for the complete extraction of product by the first in first out principal.

Exclusive welding technique that eliminates contamination

Anti-condensation & dehumidification systems

Powder recovery filters & air exhaust system

Insulation & drying technologies

Weight control in real time, integrated automation and full traceability

Multi-line distributor

Solid & liquid storage
Globosilo

www.cepilos.com
cepilos.com/contact
cepilos    ..





Bakery & Biscuits



Confectionery



Pasta & Cereals



Dairy



Premix



Baby food & functional food



Pet food



Beverages



Chemical

Outdoor silos in stainless steel with vibrating cone or fluidized bed for the complete extraction of product by the first in first out principal. Multiple extractions are also available.

Globosilos are designed and built internally in dedicated tower. Our exclusive welding technique leaves no seams between the cylinders, reducing the risk of contamination to zero. The inner surface is entirely smooth inside to prevent the persistence of leftovers. Globosilos come with powder recovery filters and air exhaust system and are constantly perfected to meet the highest hygiene standards. Globosilo is conform to all EU standards.

Include: access door to the skirt with lock, manhole in stainless steel for control of the cleaning, and advanced safety technologies such as mechanic safety group for overpressure and depression, anti-explosion hatch and guillotine valve. Globosilos can be fitted with anti-condensation system for the control and regulation of internal temperature, and insulation or drying systems according to the stored product or in case of specific weather conditions. All operations are fully automated including full traceability and weight control is provided in real time.

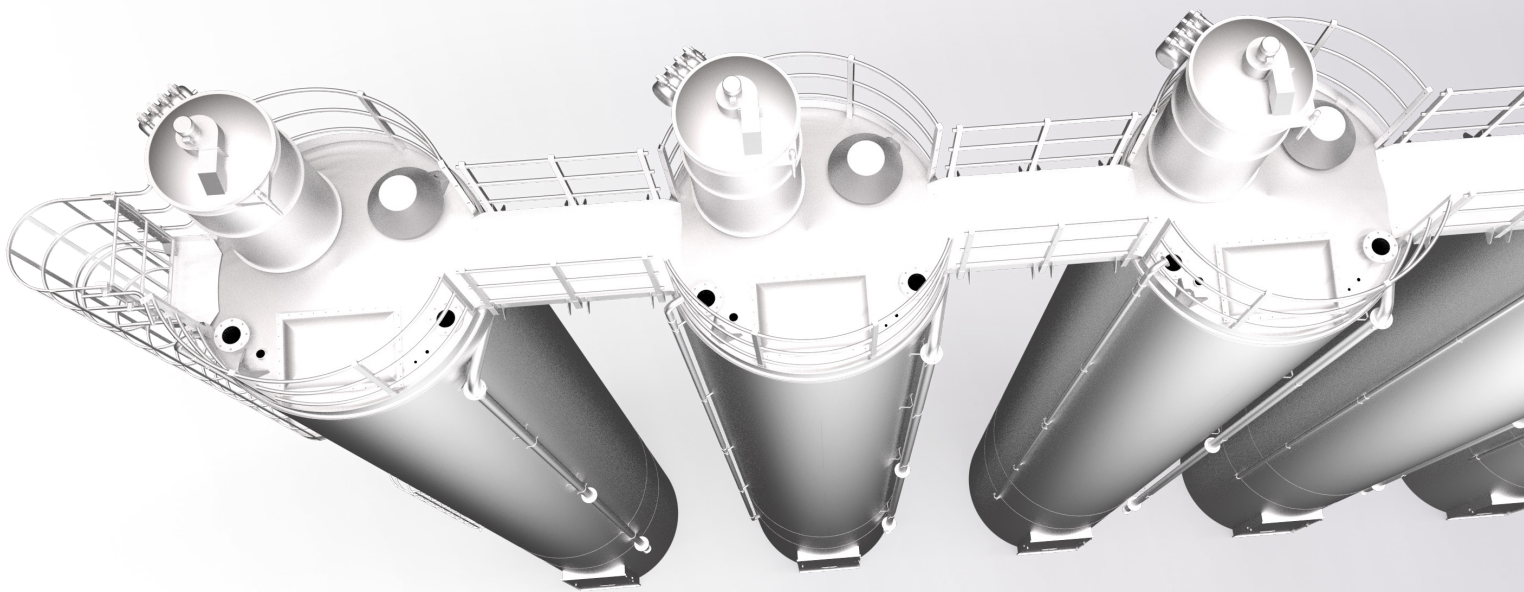

Solid & liquid storage
Globosilo

www.cepilos.com
cepilos.com/contact
cepilos



Features & Technologies

Exclusive anti-contamination welding technique

Multi-line distributor

Extraction by vibrating cone or fluidized bed

Anti-condensation and dehumidification

Insulation and drying technologies

Recovering filters for powders and air exhaust system

Bursting disk and anti-explosion hatch

Slide valve

Safety system against overpressure and depression and CEPATIC safety system against loading overpressure

Ladder to access the upper part and protection rail on the roof

Control unit, integrated automation and full traceability

Minimum and maximum level sensors

① EU standard powder recovery filter

② EU standard ladder and protection rail

③ Bursting disk

④ Extraction by vibrating cone or fluidized bed

⑤ Safety system against overpressure and depression

⑥ CEPATIC safety system against loading overpressure

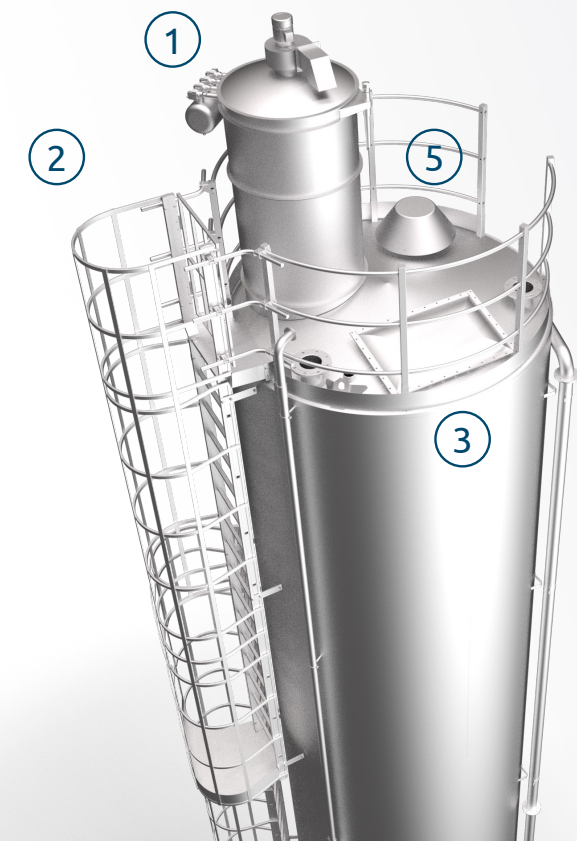



Powder recovering filters, ladder and bursting disk

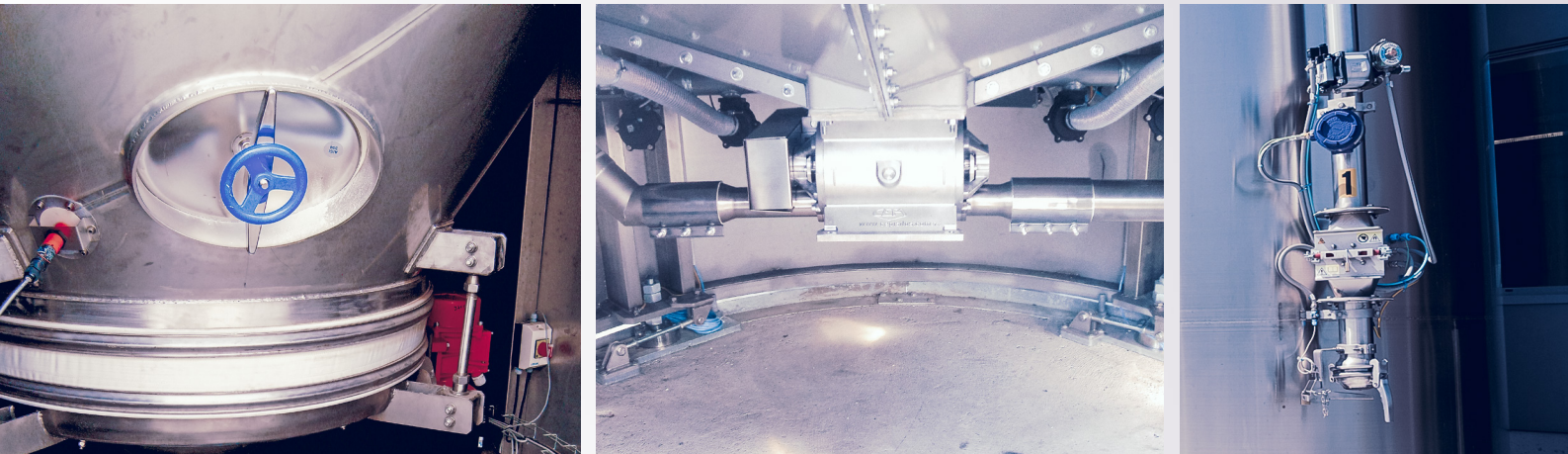

Extraction by vibrating cone, fluidized bed and CEPATIC safety system against loading overpressure



Multiliner distributor and dehumidification technology

Solid & liquid storage
Globosilo

www.cepisilos.com
cepisilos.com/contact
cepisilos    ..





CEPI Spa
 Via G Ansaldo 15
 47122 Forlì FC Italy
 T +390543940514
 F +390543940534
 cepi@cepisilos.com
 www.cepisilos.com
 f in .. cepisilos

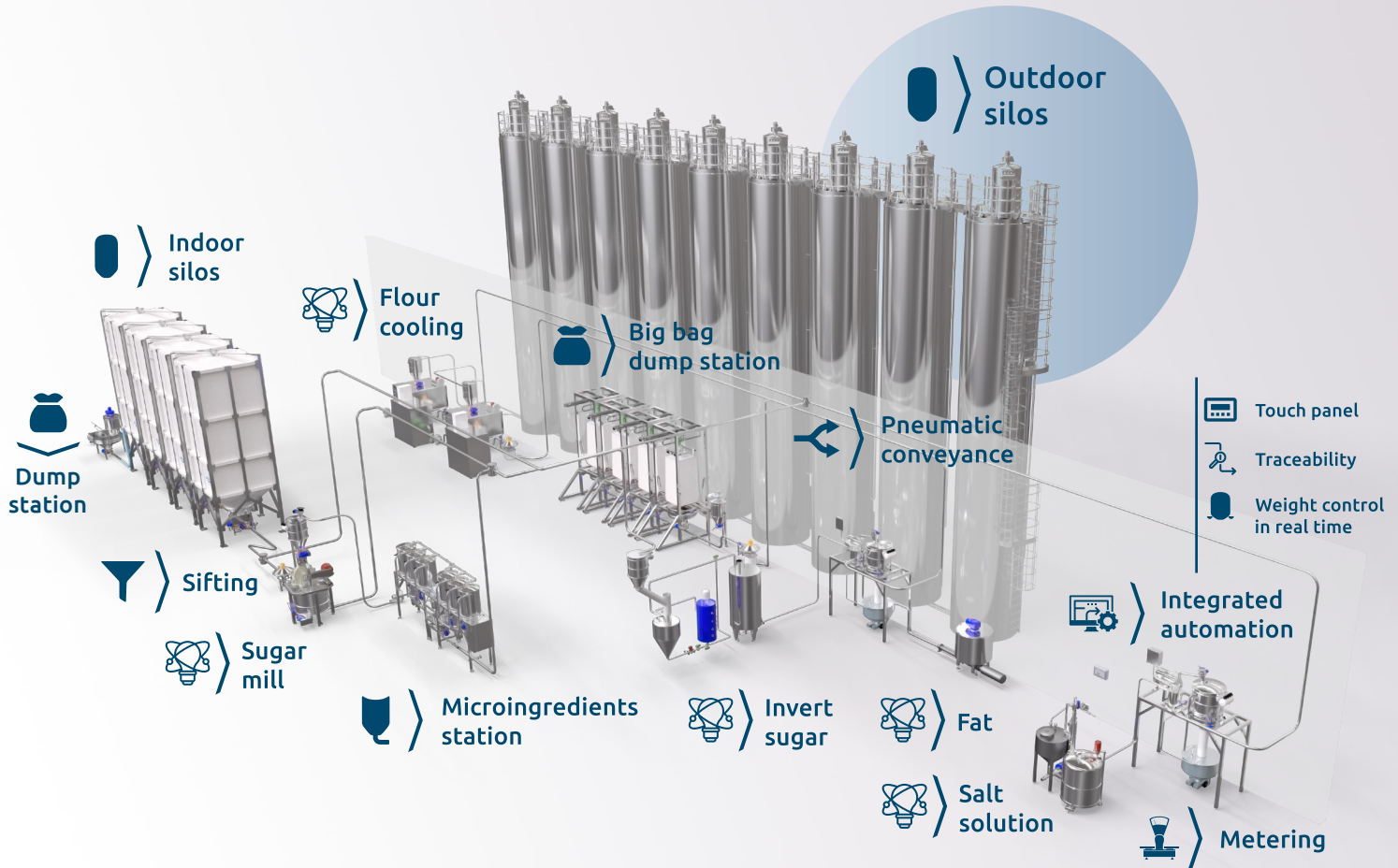

Bulk-handling systems for the food industry since 1985



STORING



CONVEYING



DOSING



AUTOMATION

Product and process analysis
 Engineering and control
 Direct manufacture
 Project management
 Installation and commissioning
 Monitoring and service



Bakery & biscuits
 Confectionery
 Pasta & Cereals
 Dairy
 Premix

Functional food
 Baby food
 Pet food
 Chemical
 Pharmaceutical